

# LMK 382 LMK 382 H

## Stainless Steel Submersible Transmitter with Ceramic Sensor

- ▶ Diameter: 39.5 mm
- ▶ hydrostatic level measurement in sewage water and contaminated media
- ▶ nominal pressure ranges from 0 ... 40 cmH<sub>2</sub>O up to 0 ... 100 mH<sub>2</sub>O (0 ... 40 mbar up to 0 ... 10 bar)

The submersible transmitter LMK 382 and LMK 382 H have been designed for continuous level measurement in sewage water and contaminated media.

On basis on a mechanically robust and highly over loadable capacitive ceramic sensor the transmitters are among others suited for the measurement of low filling heights with good long term stability. Usage in more viscous media such as slurries is possible – removing the protective cap makes the transmitter flush.

In addition to the several cable materials (PVC, PUR and FEP) the customer has the possibility to consider different versions of cable protection. The submersible transmitter is suited for explosive area (zone 0).

Preferred areas of use are:

- ▶ level monitoring in open tanks with low filling heights
- ▶ depth or level measurement in wells and open waters
- ▶ ground water level measurement
- ▶ sewage and water treatment plants
- ▶ chemical and pharmaceutical industries

- ▶ small thermal effect
- ▶ excellent linearity
- ▶ good long term stability
- ▶ **accuracy LMK 382:**  
0.175 % / 0.125 % FSO BFSL  
(0.35 % / 0.25 % FSO IEC 60770)
- ▶ **accuracy LMK 382 H:**  
0.1 % FSO BFSL  
(0.2 % FSO IEC 60770)
- ▶ **LMK 382 H:**  
**HART® communication**  
(configuration of offset, span and damping)
- ▶ **option Ex version**  
(only for 4 ... 20 mA / 2-wire)  
LMK 382: IBExU 05 ATEX 1070 X  
LMK 382 H: FTZÜ 06 ATEX 0018 X
- ▶ optional:
  - cable protection
  - diaphragm in Al<sub>2</sub>O<sub>3</sub> 99.9 %
  - customer versions on request

Characteristics

**LMK 382 / 382 H**  
Stainless Steel Level Transmitter



# LMK 382 / 382H

Stainless Steel Level Transmitter

Technical Data

Input pressure range <sup>1</sup>													
<b>LMK 382</b>													
Nominal pressure gauge [bar]	0.04	0.06	0.1	0.16	0.25	0.4	0.6	1	1.6	2.5	4	6	10
Level [mH <sub>2</sub> O]	0.4	0.6	1	1.6	2.5	4	6	10	16	25	40	60	100
Permissible overpressure [bar]	2	2	4	4	6	6	8	8	15	25	25	35	35
<b>LMK 382 H</b>													
Nominal pressure gauge [bar]	0.06		0.16		0.4		1		2		5		10
Level [mH <sub>2</sub> O]	0.6		1.6		4		10		20		50		100
Permissible overpressure [bar]	2		4		6		8		15		25		35
On customer request we adjust the devices by software on the required pressure ranges, within the turn-down-possibility (starting at 0.02 bar).													

Output signal / Supply		
<b>LMK 382</b>		
2-wire	4 ... 20 mA / V <sub>s</sub> = 9 ... 36 V <sub>DC</sub>	Ex-protection: V <sub>s</sub> = 12 ... 28 V <sub>DC</sub>
<b>LMK 382 H</b>		
2-wire	4 ... 20 mA / V <sub>s</sub> = 12 ... 36 V <sub>DC</sub> with modulated HART <sup>®</sup> signal	Ex-protection: V <sub>s</sub> = 12 ... 28 V <sub>DC</sub> with modulated HART <sup>®</sup> signal

Performance		
<b>LMK 382</b>		
Accuracy	IEC 60770 <sup>2</sup> standard: ≤ ± 0.35 % FSO option: ≤ ± 0.25 % FSO	BFSL standard: ≤ ± 0.175 % FSO option: ≤ ± 0.125 % FSO
Permissible load	R <sub>max</sub> = [(V <sub>s</sub> - V <sub>s min</sub> ) / 0.02] Ω	
Influence effects	supply: 0.05 % FSO / 10 V	load: 0.05 % FSO / kΩ
Long term stability	≤ ± 0.1 % FSO / year	
Response time	< 200 msec	
<b>LMK 382 H</b>		
Accuracy	turn-down ≤ 1:3 IEC 60770 <sup>2</sup> : ≤ ± 0.2 % FSO turn-down > 1:3 ≤ ± [0.2 + 0.015 x turn-down] % FSO with turn-down = nominal pressure range / adjusted range	BFSL: ≤ ± 0.1 % FSO
Permissible load	R <sub>max</sub> = [(V <sub>s</sub> - V <sub>s min</sub> ) / 0.02] Ω	load during HART <sup>®</sup> communication: R <sub>min</sub> = 250 Ω
Influence effects	supply: 0.05 % FSO / 10 V	load: 0.05 % FSO / kΩ
Long term stability	≤ ± (0.1 x turn-down) % FSO / year	
Response time	200 ms – without consideration of electronic damping	measuring rate 5/s
Adjustability	configuration of following parameters possible (interface / software necessary <sup>3</sup> ): - electronic damping: 0 ... 100 s - offset: 0 ... 80 % FSO - turn down of span: max. 1:5	

Thermal effects	
<b>LMK 382</b>	
Thermal error for offset and span	≤ ± 0.1 % FSO / 10 K
in compensated range	0 ... 70 °C
<b>LMK 382 H</b>	
Tolerance band	≤ ± (0.1 x turn-down) % FSO
TC, average	± (0.01 x turn-down) % FSO / 10 K
in compensated range	0 ... 70 °C

Permissible temperatures		
Medium	-10 ... 70 °C	Ex-protection: application in zone 0: -10 ... 60 °C application in zone 1 or higher: -10 ... 70 °C
Storage	-25 ... 70 °C	

<sup>1</sup> version with Al<sub>2</sub>O<sub>3</sub> 99.9% possible for pressure ranges from 0.1 bar up to 1 bar

<sup>2</sup> accuracy according to IEC 60770 – limit point adjustment (non-linearity, hysteresis, repeatability)

<sup>3</sup> software, interface, and cable have to be ordered separately (software appropriate for Windows<sup>®</sup> 95, 98, 2000, NT Version 4.0 or higher, and XP)

# LMK 382 / 382H

Stainless Steel Level Transmitter

Technical Data

## Electrical protection <sup>4</sup>

Reverse polarity protection	no damage, but also no function
Electromagnetic compatibility	emission and immunity according to EN 61326
Option Ex-protection only with 4 ... 20 mA / 2-wire DX14-LMK 382 DX15-LMK 382 H	LMK 382 (IBExU05 ATEX 1070 X) LMK 382 H (FTZÚ 06 ATEX 0018 X) Zone 0 <sup>5,6</sup> : II 1 G EEx ia IIB T4 safety technical maximum values: $U_i = 28 \text{ V}$ , $I_i = 93 \text{ mA}$ , $P_i = 660 \text{ mW}$ , $C_i = 27 \text{ nF}$ , $L_i = 5 \text{ }\mu\text{H}$

## Electrical connection

Cable with sheath material <sup>7</sup>	PVC grey PUR black FEP black
---	------------------------------------

## Dimensions (in mm)

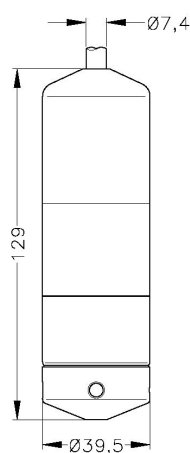

LMK 382  
Standard

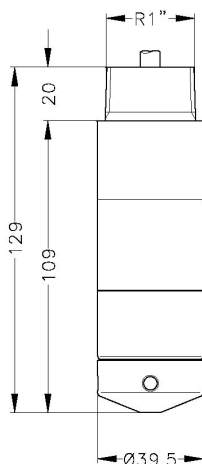

LMK 382 with thread R1"  
for stainless steel pipe

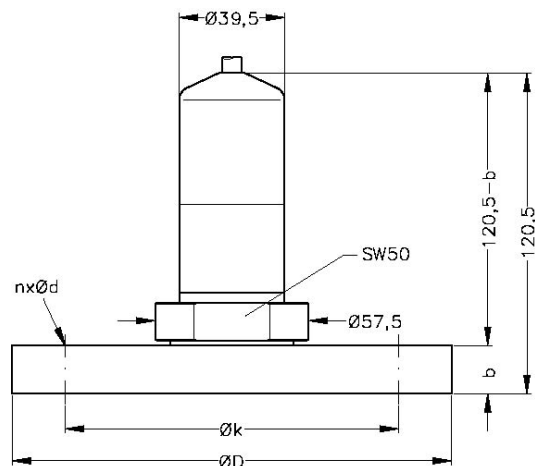

LMK 382  
Flange version

⇒ Total length of LMK 382 H increases by 71 mm.

Dimensions	DN25 / PN40	DN50 / PN16	DN80 / PN16
D	115	165	200
b	18	18	20
k	85	125	160
n	4	4	8
d	14	18	18

<sup>4</sup> additional external overvoltage protection unit in terminal box KL 1 or KL 2 with atmospheric pressure reference available as accessory

<sup>5</sup> approved for atmospheric pressure from 0.8 bar up to 1.1 bar

<sup>6</sup> for option stainless steel pipe following designation is valid: "II 1 G EEx ia IIC T4" (zone 0)

<sup>7</sup> cable with integrated air tube for atmospheric pressure reference

# LMK 382 / 382H

Stainless Steel Level Transmitter

Technical Data

Materials	
Housing	stainless steel 1.4571 (316Ti)
Seals	FKM / EPDM / others on request
Diaphragm	Standard: ceramics $Al_2O_3$ 96 % Option: ceramics $Al_2O_3$ 99.9 % (possible for pressure ranges from 0.1 bar up to 1 bar)
Cable sheath	PVC / PUR / FEP

Miscellaneous	
Connecting cables (by factory)	cable capacitance: signal line/shield also signal line/signal line: 160 pF/m cable inductance: signal line/shield also signal line/signal line: 1 $\mu$ H/m
Current consumption	max. 21 mA
Weight	approx. 400 g (without cable)
Ingress protection	IP 68

Mounting accessories (not included in delivery)	
Transmitter flange , stainless steel 1.4571 (316Ti): DN25 / PN40 ( $\varnothing$ 115, 18 thick, 4 drill holes $\varnothing$ 14 at $\varnothing$ 85) DN50 / PN16 ( $\varnothing$ 165, 18 thick, 4 drill holes $\varnothing$ 18 at $\varnothing$ 125) DN80 / PN16 ( $\varnothing$ 200, 20 thick, 8 drill holes $\varnothing$ 18 at $\varnothing$ 160)	
Mounting flange for transmitter fixing, stainless steel 1.4571 (316Ti): DN25 / PN40 ( $\varnothing$ 115, 18 thick, 4 drill holes $\varnothing$ 14 at $\varnothing$ 85) DN50 / PN16 ( $\varnothing$ 165, 18 thick, 4 drill holes $\varnothing$ 18 at $\varnothing$ 125) DN80 / PN16 ( $\varnothing$ 200, 20 thick, 8 drill holes $\varnothing$ 18 at $\varnothing$ 160)	
Screw fitting, stainless steel 1.4571 (316 Ti)	
Terminal clamp, stainless steel 1.4301 (304) or steel, zinc plated	

Pin configuration		
Electrical connection	cable colours (DIN 47100)	
2-wire-system	Supply +	white
	Supply -	brown
	Ground	yellow / green (shield)

## Wiring diagram

2-wire-system (current)

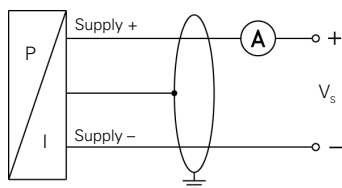

2-wire-system (current) HART®

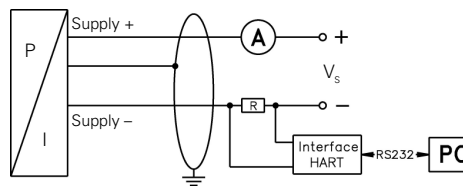

HART® is a registered trade mark of HART Communication Foundation  
Windows® is a registered trade mark of Microsoft Corporation

This data sheet contains product specification, properties are not guaranteed. Subject to change without notice.

